

The Elmer A. Sperry Award



In recognition of leading the innovation for
water-lubricated main propulsion shaft bearings for
marine transport through the application of
polymeric compounds

*Presentation of
The Elmer A. Sperry Award
For 2019*

Given in recognition of a distinguished engineering contribution, which through application proven in actual service has advanced the art of transportation, whether by land, sea, air, or space.

PRESENTED TO

George A. (Sandy) Thomson

BY

The Elmer A. Sperry Board of Award

REPRESENTED BY THE

American Society of Mechanical Engineers
Institute of Electrical and Electronics Engineers
SAE International
Society of Naval Architects and Marine Engineers
American Institute of Aeronautics and Astronautics
American Society of Civil Engineers

In recognition of leading the innovation for water-lubricated main propulsion shaft bearings for marine transport through the application of polymeric compounds

At the SNAME Maritime Convention 2019
Tacoma, Washington 📍 October 31, 2019

*The Elmer A.
Sperry Award*

George A. (Sandy) Thomson Innovator, Thordon Bearings Inc.

George A. (Sandy) Thomson, a native of Burlington, Ontario, Canada, attended Northrop University in Inglewood, California where he studied Aircraft Maintenance Engineering but graduated as a Mechanical Engineer. After some hands-on experience as a mechanical seal designer and salesman with a Boston based manufacturer of mechanical shaft seals, Sandy returned to Canada in 1965 to join the family business, Thomson-Gordon Ltd. founded by his grandfather in 1911. At that time, the Hamilton, Ontario based company was primarily a distributor of Engineers' Supplies. The prospect of manufacturing engineered components made from elastomers intrigued Sandy and he felt that rubber pump bearings offered the most room for innovation. Sandy along with Dr. Pande and Dr. Bill Allan developed the Thordon polymer in the late 1960s.

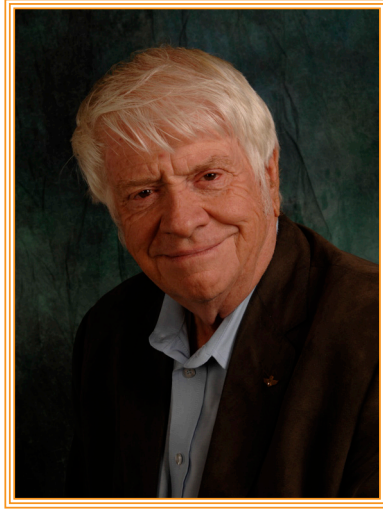

After several prototype bearings, the world's first polymer alloy bearing was installed in 1967 into a vertical pump in partnership with a local steel plant replacing traditional rubber bearings that typically wore out in a few weeks.

Sandy thought of many markets for the polymer, and after the successful operation of the polymer installed in vertical pump applications, the marine market on Lake Ontario seemed like the perfect place to test the bearing in horizontal applications. So thanks to Sandy, the world's first Thordon propeller shaft bearing was installed on a Great Lakes tug owned by McKeil Marine in Hamilton in the late 1970s. Today McKeil is the largest tug/barge owner on the Great Lakes and still a loyal customer 40 years later. Following this conversion, many other vessels on the Great Lakes were converted to Thordon's propeller shaft bearing system helping to put Thordon on the map in the marine industry.

Since the first Great Lakes ship installation in the late 1970s, Thordon's polymer tailshaft bearings have now been installed as newbuild or retrofit solutions to hundreds of vessels worldwide including Princess Cruises, Lomar, Carisbrooke Shipping, COSCO, CSL, MSC Cruises, Matson Navigation and Viking Cruises to name a few.

Another groundbreaking move was to supply propeller shaft bearings to the Royal Canadian Navy (RCN)'s - twelve new state of the art naval frigates planned to be built in the 1990s. The original bearings were specified rubber, but once installed, the rubber bearings did not meet performance and acoustic expectations. Sandy's newest company, Thordon Bearings Inc., was ready and Thordon's COMPAC propeller shaft bearings were retrofitted on the initial new build, and eventually installed on the remainder of the Halifax Class warships. Concurrently, the Canadian Navy also evaluated the performance of these elastomer shaft bearings in the Oberon Class submarine with positive results leading to successful adoption in other submarine applications. The performance of Thordon's COMPAC bearings with the RCN set the stage for global growth in over 40 Navies and Coast Guards worldwide.

Sandy was recognized by the Society of Naval Architects and Marine Engineers (SNAME) in 2016 when he was elected a Fellow for his outstanding personal contribution to the marine/ocean engineering fields through significant achievements in design, research, production, operation and education. He and Thordon Bearings have presented many technical papers at SNAME conferences furthering the movement of seawater lubricated propeller shaft bearings. Sandy is a firm believer in the role of all technical societies to provide forums for open and collegial discussion and debate, while acting as the guardians of best practice and innovation. He actively encourages his team, including Young Professionals, to develop a culture of technical dialogue coupled with a seasoning of business acumen.

It is due in large part to Sandy's early innovations that Thordon has become a global leader in seawater lubricated propeller shaft bearings and seals as well as offering a complete range of non-metallic sleeve bearing solutions for marine, clean power generation, pump, offshore, and other industrial markets.

Thordon Bearings Inc.

Thordon Bearings Inc., a Thomson-Gordon Group company, is a family-owned business manufacturing high performance, oil and grease-free bearing systems, seals and other shaft line products for the global marine, clean power, pump and industrial markets.



Unlike many publicly traded and larger private companies, the motivation behind the on-going growth and success of Thordon Bearings has not been to enhance shareholder returns, but instead has been to provide a contribution to society in the form of superior products, valued employment, and technological advances that better the environment we live in.

Sandy Thomson, as a third-generation owner of the Thomson-Gordon Group of companies, was the driving force in transforming the company from a simple distribution and sales company to an innovative engineering firm whose products eliminate grease and oil discharges to the environment. Thordon's seawater lubricated propeller shaft bearings prevent millions of litres of oil from polluting our oceans, seas, and rivers every year and protect the marine life dependent on them.

“

*Engineers can be too rigid and won't succeed
unless they tap into their creative side.
I have the mind of an engineer, but the soul of an artist.*

”



Sandy at the helm of the Rudokop, a steamship tug he captained for 14 years.

Sandy's focus on innovation and developing export markets has been the key to Thordon's success. In 1990, he bought the Russian deep-sea salvage tug, Rudokop, and converted it to a "floating showcase" of Thordon marine bearing and seal products, he then captained this ship visiting more than 300 ports in Eastern and Western Europe.

Thordon polymer bearing systems offer exceptional wear life, a low coefficient of friction and can be easily machined on site. In-house design engineers consult with customers to provide innovative bearing system designs that often set new performance standards. Thordon Bearings' engineering and quality focus has earned worldwide recognition. Quality procedures are certified to the ISO 9001 Quality System. Thordon bearing systems are proven, cost effective, environmentally positive solutions for both marine and industrial applications. Thordon bearing and seal systems are available worldwide through over 75 agents and distributors.

Technology

Thordon Seawater Lubricated Propeller Shaft Bearings

With a strong focus on the health of our oceans, seas and rivers, Sandy was ahead of his time developing seawater lubricated propeller shaft polymer bearings that did not require oil lubrication. Over the past 35 years, Thordon bearings have been installed on thousands of commercial, workboat and Naval vessels around the globe. Ship owners enjoy cost and maintenance savings because of the long wearlife and proven performance of Thordon's technology.

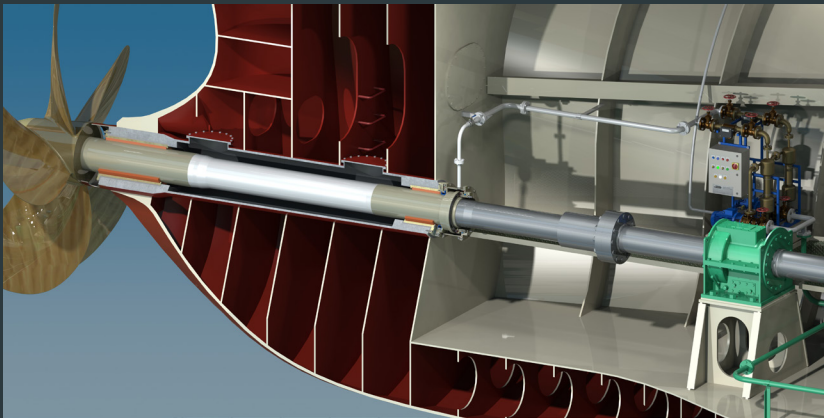

Thordon's COMPAC seawater lubricated propeller shaft bearing system

While Thordon offers a variety of polymer grades for various water environments, Thordon's COMPAC high performance bearing is at the heart of the award-winning open seawater lubricated propeller shaft bearing system. Based on COMPAC's proven performance in the cruise industry after 21 years installed on Disney Cruise Lines and Princess Cruise ships, Thordon now offers an unprecedented lifetime bearing wearlife guarantee. Not a single one of the 32 ocean-going cruise vessels equipped with COMPAC bearings have experienced downtime, cancellations or changes to cruise itineraries due to propeller shaft bearing failure and have never needed to be replaced due to wear.



RiverTough tailshaft bearings being installed on workboat in U.S. inland waterways

RiverTough tailshaft bearings were created for the US Inland Waterways and other abrasive water environments. When run in combination with hard coated nickel-chrome-boron (NiCrB) Thordon shaft sleeves, RiverTough routinely outlast rubber bearings by a factor of two or more in the most abrasive operating water conditions. This material offers increased resilience compared to rubber bearings offering easier alignment and less edge loading.

“

It is a challenge to identify opportunities that assist ship owners in meeting environmental standards cost-effectively and that don't end up creating new environmental problems. The COMPAC propeller shaft bearing system meets this challenge and it is for that reason – and the system's simplicity – that we were able to present Thordon Bearings with the Tanker Shipping & Trade Environment Award.

”

—Dr. Karen Purnell, the Managing Director of the International Tanker Owners Pollution Federation (ITOPF)

SeaThigor & TG100 Mechanical Face Seals

Sandy was the catalyst in the development of a robust tailshaft mechanical seal that has a unique emergency seal feature. His involvement with mechanical shaft seals dates back to his university days when his final year machine design project was a shaft seal design followed by prototype machining and testing. Both the SeaThigor seal, designed for blue water operation and the TG100 seal designed for the use in abrasive waterways feature a “Safe Return to Port” mode. If the silicon carbide faces ever get damaged, the safe return to port seal means that the shaft can still turn with the seal in place. It works by activating an inflatable seal and the vessel can proceed to a repair facility on its own power.

In February 2019 the inflatable emergency seal prevented a twin-screw workboat from certain sinking after a catastrophic shaft failure. This vessel was the first workboat to be fitted with a TG100 seal in 2012. Based on the reliability of this seal the ship owner opted for two more TG100s to protect not only the lives of the crew but also the vessel.



Sandy onboard the Canadian Coast Guard Ship Hudson with SeaThigor mechanical face seal installed.

In 2016, Sandy was the catalyst for Thordon broadening its water lubricated shaft system offering for naval and merchant vessels by introducing a robust mechanical face seal – The SeaThigor Seal with Safe Return to Port (SRTP) capability. In the event of a face failure of the primary seal, a secondary SRTP seal module is activated, allowing the propeller shaft to be rotated at reduced speeds allowing the vessel to make it safely to a repair facility under its own power, without causing further damage.

“

Our innovations have always been customer driven but also based on a desire to develop something the customer doesn't know is even possible. If we can't better something that's already out there, why do it? Our philosophy has always been to value quality and reliability over anything else.

”

Other Applications:

Reliability, long wear life and superior customer service have made Thordon the first choice in pollution free rudder bearing applications for over 25 years with an impressive reference list of over 4000 vessels. Thordon SXL self-lubricating pintle, stock and carrier disc bearings operate grease-free, above and below the waterline.

Thordon Bearings offers a 15-year bearing wearlife guarantee for rudder bearings installed on newbuilds, a guarantee that is unmatched by any other rudder bearing supplier.



Ensuring the smooth, reliable operation of all machinery installed above the waterline is a tall order for a ship's Deck Crew. Operating conditions are tough, and maintenance requirements of the equipment onerous, with the onset of bearing seizure usually imminent should periodic maintenance be delayed or overlooked. Inadequately greased bronze

bushings and seawater shaft corrosion may cause bushing seizure. Thordon deck equipment bushings are an ideal replacement for bronze and other non-metallic bearings in deck equipment applications. ThorPlas-Blue is available in a range of sizes and is easily machined to the dimensions required for fairleads, capstans, davits, gantries, pivot bushings, cranes, chain hoists, door and ramp hinge bearings and steering gear ram and linkage pins.

With the elimination of grease, ThorPlas-Blue offers improved safety for the crew not having to grease these bushings located in hard to reach locations. To facilitate maintenance while under way, ThorPlas-Blue can be easily and safely machined using on-board machining facilities and then installed quickly.

“Thordon Bearings is a pioneer in water lubricated propeller shaft bearings, with over 35 years’ of experience in this technology. We will have the opportunity to provide our customers with a real, long-term solution to the environmental problems they face with oil lubricated stern tube bearings and seals. With concerns increasingly being raised about the impact oil discharges have on the marine environment, converting an oil lubricated system to seawater is the only guaranteed solution for today and tomorrow.” Mohammad Rizal, COO of Drydocks World-Dubai, U.A.E.



Grease-free ThorPlas-Blue bearings installed on a Landing Craft Utility vessel

ladder wire rope sheave bearings, pipe support swivels, spud housing bushes, and pump bearings.

In the Offshore market, Thordon manufactures Floating Production Storage and Offloading (FPSO) turret bearings, mooring and rotation equipment and has extensive experience with spread mooring, cantilever, external and internal turret bearing designs. Thordon bearings and pads are easy to install and replace meaning lower financial impact due to reduced downtime.

Anchor Handling Tug Supply (AHTS) vessels do the tough job of setting anchors for drilling rigs, as well as towing mobile drilling rigs and equipment from one location to another. The AHTS stern rollers and seals operate in harsh sea conditions, under high bearing loading, while demanding low maintenance and grease free operation. Thordon provides a reliable and cost effective solution to the traditional metallic or phenolic bearings that require constant maintenance.



Thordon SXL bearing installed in FPSO turret application

“

We don't believe in selling spare parts

”

Our Future, Our Ocean

The environment as a whole is extremely important to Sandy and it forms the basis for many of business decisions at Thordon Bearings such as refusing to sell propeller shaft bearings for ships if they are going to be lubricated with oil knowing the oil will leak into the sea. This closes the door on a vast existing market, yet Sandy and the Thordon family strongly believe we should all play a role in protecting our oceans and seas for future generations.

The shipping industry is returning to seawater lubricated systems for a number of commercial, technical and sustainable reasons. The performance of open seawater lubricated propeller shaft bearing systems to date has been seen as a technically viable alternative to a closed oil lubricated white metal bearing system. Most of the world's Class Societies have even modified their rules for extended shaft withdrawals given the steady progress of water lubricated bearing technology adapted by today's commercial ship owners.

Ships trading in the world's oceans and seas can now eliminate propeller shaft operational and accidental lubricating oil pollution with the COMPAC system while reducing ship owner maintenance costs and saving money over the service life of the ship. With current and future regulations citing that the vessel must not discharge oil from any oil-to-sea interface that may be harmful to aquatic life, vessel operators can be totally compliant by using a seawater lubricated propeller shaft system. Today, the COMPAC open seawater lubricated propeller shaft system offers considerable advantages to ship owners, not only in bearing wear life predictability and reliability, but they are also cheaper to maintain, easier to install and are future compliant. Seawater lubricated propeller shaft bearings are even promoted by the U.S. EPA for all commercial ships operating in US waters.

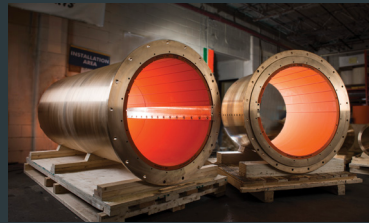

By providing an alternative to the 1950s solution of using oil lubricated stern tubes to support the propulsion shafts, the marine community is able to meet its social responsibility for the protection of the planet as well as helping to eliminate another source of pollution from the world's oceans and seas.



Thordon Bearings' COMPAC seawater lubricated propeller shaft bearing system won the coveted 2019 Seatrade Award for Clean Shipping, in recognition of the technology's capacity to completely eradicate operational oil pollution from ships' stern tubes.

Continuous Innovation

Marsh Brothers Aviation



His passion for aviation is never far from his heart. It was inevitable that Sandy, a licensed pilot at age 18, developed Marsh Brothers Aviation — a sister company to Thordon focused on applying the proven and successful polymer technology to provide solutions to the aviation industry. And so AeroTough GF (ATGF),

a self-lubricating polymer that replaces traditional greased nickel-bronze bearings, and ThorFlex, an elastomeric polymer to replace traditional rubber o-rings in dynamic sealing applications, were born. Testing all of the products initially developed on his own aircraft, first a V35 Bonanza and later an Aerostar 601P-700 enabled Sandy to do two things he very much loves; getting his hands dirty and flying. With his Aerostar landing gear fully upgraded — all dynamic joints equipped with ATGF and the shock strut bearings and seals replaced with the ATGF and ThorFlex upgrades — Sandy has accumulated over 650 flight hours and well over 600 landings with this platform. There is no evidence of wear and the dynamic joints have never been greased. Seventy positions on the aircraft have become self-lubricating.



Sandy ready to board his Sea Fury aircraft at the Canadian Warplane Heritage Museum

ATGF polymer parts are 1/7th the weight of equivalent nickel-bronze parts. The lower weight offers greater payload. Contamination of joints by dirt attracted to grease or oil is eliminated. Routine maintenance is simplified. Combine these benefits with the confidence the flight crew gains from never worrying about a seized joint and down time associated with periodic greasing of joints and the overwhelming benefits Marsh Brothers Aviation products are undeniable.

Clean Power Generation

Sandy is hard at work on his next innovation: a series of 5kW to 75kW low noise, zero pollution Kaplan-type turbines for the hydro power industry – another sector that has always been a passion of his. The Thomson-Gordon owned company TG-DNALOP purchased the small Struzyska hydro facility in Pila, Poland in 2018. As Sandy did with the Rudokop in the 1990s, this small hydro plant will act as a demonstration site for Thordon's water-lubricated turbine guide bearing, wicket gate bearing and shaft seal technologies once the turbines have been refurbished.

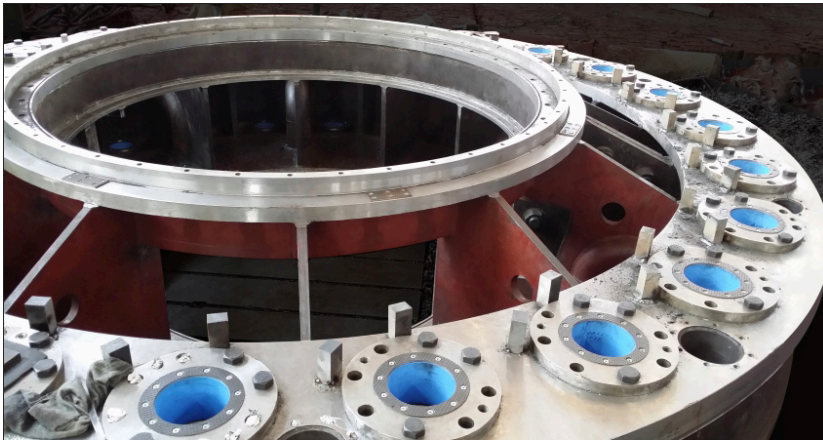

“

To be the best demands a genuine commitment to innovation, problem solving, service and quality. Our goal is to provide products and services that represent the best possible value for our customers' needs

”

On the Horizon

Having Sandy at the helm over the past 54 years, has allowed both the Thomson-Gordon Group and Thordon Bearings to endure many challenges and obstacles that have shaped what the company is today. His first patent was for a machine called a “Hydralacer” which formed an interlocking mechanical joint for rubber conveyor belts. Thordon was patented as well but in general preference is given to protection by trade secrets, an option only practical for a company where employee bonds are strong.

Sandy’s maritime and aviation passion, strong leadership and innovation have transformed the company into a successful marine and industrial bearing and seal manufacturer. Thordon is considered a world leader in non-polluting oil and grease free marine bearings and seals providing long lasting solutions with minimal spare parts and operating costs and forever making an impact on preventing pollution of the earth’s rivers, oceans and seas.



Anna Galoni and Sandy at Thomson-Gordon Group's 100 year anniversary celebration in 2011

Sandy has recognized that the future of Thordon lies with our youth having skilled trades and education -70% of Thordon employees are university, college or trade school educated. Thordon supports youth employment and skills development, hiring Co-op students from local Universities and Colleges on a yearly basis.

The company is now being passed to the fourth generation. Sandy’s Polish born stepdaughter Anna Galoni is dedicated to continue to lead with Sandy’s vision, core values and passion in mind. Anna, an epidemiologist, now serves as Chair, and has been with the firm for 15 years.

Elmer A. Sperry, 1860–1930



After graduating from the Cortland, N.Y. Normal School in 1880, Sperry had an association with Professor Anthony at Cornell, where he helped wire its first generator. From that experience he conceived his initial invention, an improved electrical generator and arc light. He then opened an electric company in Chicago and continued on to invent major improvements in electric mining equipment, locomotives, streetcars and an electric automobile. He developed gyroscopic stabilizers for ships and aircraft, a successful marine gyro-compass and gyro-controlled steering and fire control systems used on Allied warships during World War I. Sperry also developed an aircraft searchlight and the world's first guided missile. His gyroscopic work resulted in the automatic pilot in 1930. The Elmer A. Sperry Award was established in 1955 to encourage progress in transportation engineering.

The Elmer A. Sperry Award

To commemorate the life and achievements of Elmer Ambrose Sperry, whose genius and perseverance contributed so much to so many types of transportation, the Elmer A. Sperry Award was established by his daughter, Helen (Mrs. Robert Brooke Lea), and his son, Elmer A. Sperry, Jr., in January 1955, the year marking the 25th anniversary of their father's death. Additional gifts from interested individuals and corporations also contribute to the work of the board.

Elmer Sperry's inventions and his activities in many fields of engineering have benefited tremendously all forms of transportation. Land transportation has profited by his pioneer work with the storage battery, his development of one of the first electric automobiles (on which he introduced 4-wheel brakes and self-centering steering), his electric trolley car of improved design (features of its drive and electric braking system are still in use), and his rail flaw detector (which has added an important factor of safety to modern railroading). Sea transportation has been measurably advanced by his gyrocompass (which has freed humans from the uncertainties of the magnetic compass) and by such navigational aids as the course recorder and automatic steering for ships. Air transportation is indebted to him for the airplane gyro-pilot and the other air navigational instruments he and his son, Lawrence, developed together.

The donors of the Elmer A. Sperry Award have stated that its purpose is to encourage progress in the engineering of transportation. Initially, the donors specified that the award recipient should be chosen by a Board of Award representing the four engineering societies in which Elmer A. Sperry was most active:

American Society of Mechanical Engineers (of which he was the 48th president)

American Institute of Electrical Engineers (of which he was a founder member)

Society of Automotive Engineers

Society of Naval Architects and Marine Engineers

In 1960, the participating societies were augmented by the addition of the Institute of Aerospace Sciences. In 1962, upon merging with the Institute of Radio Engineers, the American Institute of Electrical Engineers became known as the Institute of Electrical and Electronics Engineers; and in 1963, the Institute of Aerospace Sciences, upon merger with the American Rocket Society, became the American Institute of Aeronautics and Astronautics. In 1990, the American Society of Civil Engineers became the sixth society to become a member of the Elmer A. Sperry Board of Award. In 2006, the Society of Automotive Engineers changed its name to SAE International.

Important discoveries and engineering advances are often the work of a group, and the donors have further specified that the Elmer A. Sperry Award honor the distinguished contributions of groups as well as individuals.

Since they are confident that future contributions will pave the way for changes in the art of transportation equal at least to those already achieved, the donors have requested that the board from time to time review past awards. This will enable the board in the future to be cognizant of new areas of achievement and to invite participation, if it seems desirable, of additional engineering groups representative of new aspects or modes of transportation.

The Sperry Secretariat

The donors have placed the Elmer A. Sperry Award fund in the custody of the American Society of Mechanical Engineers. This organization is empowered to administer the fund, which has been placed in an interest bearing account whose earnings are used to cover the expenses of the board. A secretariat is administered by the ASME, which has generously donated the time of its staff to assist the Sperry Board in its work.

The Elmer A. Sperry Board of Award welcomes suggestions from the transportation industry and the engineering profession for candidates for consideration for this award.

Previous Elmer A. Sperry Awards

- 1955** To **William Francis Gibbs** and his Associates for design of the S.S. United States.
- 1956** To **Donald W. Douglas** and his Associates for the DC series of air transport planes.
- 1957** To **Harold L. Hamilton, Richard M. Dilworth** and **Eugene W. Kettering** and Citation to their Associates for developing the diesel-electric locomotive.
- 1958** To **Ferdinand Porsche** (in memoriam) and **Heinz Nordhoff** and Citation to their Associates for development of the Volkswagen automobile.
- 1959** To **Sir Geoffrey de Havilland, Major Frank B. Halford** (in memoriam) and **Charles C. Walker** and Citation to their Associates for the first jet-powered passenger aircraft and engines.
- 1960** To **Frederick Darcy Braddon** and Citation to the Engineering Department of the Marine Division of the Sperry Gyroscope Company, for the three-axis gyroscopic navigational reference.
- 1961** To **Robert Gilmore LeTourneau** and Citation to the Research and Development Division, Firestone Tire and Rubber Company, for high speed, large capacity, earth moving equipment and giant size tires.
- 1962** To **Lloyd J. Hibbard** for applying the ignitron rectifier to railroad motive power.
- 1963** To **Earl A. Thompson** and Citations to **Ralph F. Beck, William L. Carnegie, Walter B. Herndon, Oliver K. Kelley** and **Maurice S. Rosenberger** for design and development of the first notably successful automatic automobile transmission.
- 1964** To **Igor Sikorsky** and **Michael E. Glubareff** and Citation to the Engineering Department of the Sikorsky Aircraft Division, United Aircraft Corporation, for the invention and development of the high-lift helicopter leading to the Skycrane.
- 1965** To **Maynard L. Pennell, Richard L. Rouzie, John E. Steiner, William H. Cook** and **Richard L. Loesch, Jr.** and Citation to the Commercial Airplane Division, The Boeing Company, for the concept, design, development, production and practical application of the family of jet transports exemplified by the 707, 720 and 727.
- 1966** To **Hideo Shima, Matsutaro Fuji** and **Shigenari Oishi** and Citation to the Japanese National Railways for the design, development and construction of the New Tokaido Line with its many important advances in railroad transportation.

- 1967** To *Edward R. Dye* (in memoriam), *Hugh DeHaven*, and *Robert A. Wolf* for their contribution to automotive occupant safety and Citation to the research engineers of Cornell Aeronautical Laboratory and the staff of the Crash Injury Research projects of the Cornell University Medical College.
- 1968** To *Christopher S. Cockerell* and *Richard Stanton-Jones* and Citation to the men and women of the British Hovercraft Corporation for the design, construction and application of a family of commercially useful Hovercraft.
- 1969** To *Douglas C. MacMillan*, *M. Nielsen* and *Edward L. Teale, Jr.* and Citations to *Wilbert C. Gumprich* and the organizations of George G. Sharp, Inc., Babcock and Wilcox Company, and the New York Shipbuilding Corporation for the design and construction of the N.S. Savannah, the first nuclear ship with reactor, to be operated for commercial purposes.
- 1970** To *Charles Stark Draper* and Citations to the personnel of the MIT Instrumentation Laboratories, Delco Electronics Division, General Motors Corporation, and Aero Products Division, Litton Systems, for the successful application of inertial guidance systems to commercial air navigation.
- 1971** To *Sedgwick N. Wight* (in memoriam) and *George W. Baughman* and Citations to *William D. Hailes*, *Lloyd V. Lewis*, *Clarence S. Snavely*, *Herbert A. Wallace*, and the employees of General Railway Signal Company, and the Signal & Communications Division, Westinghouse Air Brake Company, for development of Centralized Traffic Control on railways.
- 1972** To *Leonard S. Hobbs* and *Perry W. Pratt* and the dedicated engineers of the Pratt & Whitney Aircraft Division of United Aircraft Corporation for the design and development of the JT-3 turbo jet engine.
- 1975** To *Jerome L. Goldman*, *Frank A. Nemeč* and *James J. Henry* and Citations to the naval architects and marine engineers of Friede and Goldman, Inc. and Alfred W. Schwendtner for revolutionizing marine cargo transport through the design and development of barge carrying cargo vessels.
- 1977** To *Clifford L. Eastburg* and *Harley J. Urbach* and Citations to the Railroad Engineering Department of The Timken Company for the development, subsequent improvement, manufacture and application of tapered roller bearings for railroad and industrial uses.
- 1978** To *Robert Puiseux* and Citations to the employees of the Manufacture Française des Pneumatiques Michelin for the development of the radial tire.

- 1979 To *Leslie J. Clark* for his contributions to the conceptualization and initial development of the sea transport of liquefied natural gas.
- 1980 To *William M. Allen, Malcolm T. Stamper, Joseph F. Sutter* and *Everette L. Webb* and Citations to the employees of Boeing Commercial Airplane Company for their leadership in the development, successful introduction & acceptance of wide-body jet aircraft for commercial service.
- 1981 To *Edward J. Wasp* for his contributions toward the development and application of long distance pipeline slurry transport of coal and other finely divided solid materials.
- 1982 To *Jörg Brenneisen, Ehrhard Futterlieb, Joachim Körber, Edmund Müller, G. Reiner Nill, Manfred Schulz, Herbert Stemmler* and *Werner Teich* for their contributions to the development and application of solid state adjustable frequency induction motor transmission to diesel and electric motor locomotives in heavy freight and passenger service.
- 1983 To *Sir George Edwards*, OM, CBE, FRS; *General Henri Ziegler*, CBE, CVO, LM, CG; *Sir Stanley Hooker*, CBE, FRS (in memoriam); *Sir Archibald Russell*, CBE, FRS; and *M. André Turcat*, L d'H, CG; commemorating their outstanding international contributions to the successful introduction and subsequent safe service of commercial supersonic aircraft exemplified by the Concorde.
- 1984 To *Frederick Aronowitz, Joseph E. Killpatrick, Warren M. Macek* and *Theodore J. Podgorski* for the conception of the principles and development of a ring laser gyroscopic system incorporated in a new series of commercial jet liners and other vehicles.
- 1985 To *Richard K. Quinn, Carlton E. Tripp*, and *George H. Plude* for the inclusion of numerous innovative design concepts and an unusual method of construction of the first 1,000-foot self-unloading Great Lakes vessel, the M/V Stewart J. Cort.
- 1986 To *George W. Jeffs, Dr. William R. Lucas, Dr. George E. Mueller, George F. Page, Robert F. Thompson* and *John F. Yardley* for significant personal and technical contributions to the concept and achievement of a reusable Space Transportation System.
- 1987 To *Harry R. Wetenkamp* for his contributions toward the development and application of curved plate railroad wheel designs.
- 1988 To *J. A. Pierce* for his pioneering work & technical achievements that led to the establishment of the OMEGA Navigation System, the world's first ground-based global navigation system.
- 1989 To *Harold E. Froehlich, Charles B. Momsen, Jr.,* and *Allyn C. Vine* for the invention, development and deployment of the deep-diving submarine, Alvin.

- 1990** To **Claud M. Davis, Richard B. Hanrahan, John F. Keeley,** and **James H. Mollenauer** for the conception, design, development and delivery of the Federal Aviation Administration enroute air traffic control system.
- 1991** To **Malcom Purcell McLean** for his pioneering work in revolutionizing cargo transportation through the introduction of intermodal containerization.
- 1992** To **Daniel K. Ludwig** (in memoriam) for the design, development and construction of the modern supertanker.
- 1993** To **Heinz Leiber, Wolf-Dieter Jonner** and **Hans Jürgen Gerstenmeier** and Citations to their colleagues in Robert Bosch GmbH for their conception, design and development of the Anti-lock Braking System for application in motor vehicles.
- 1994** To **Russell G. Altherr** for the conception, design and development of a slackfree connector for articulated railroad freight cars.
- 1996** To **Thomas G. Butler** (in memoriam) and **Richard H. MacNeal** for the development and mechanization of NASA Structural Analysis (NASTRAN) for widespread utilization as a working tool for finite element computation.
- 1998** To **Bradford W. Parkinson** for leading the concept development and early implementation of the Global Positioning System (GPS) as a breakthrough technology for the precise navigation and position determination of transportation vehicles.
- 2000** To those individuals who, working at the French National Railroad (SNCF) and ALSTOM between 1965 and 1981, played leading roles in conceiving and creating the initial TGV High Speed Rail System, which opened a new era in passenger rail transportation in France and beyond.
- 2002** To **Raymond Pearlson** for the invention, development and worldwide implementation of a new system for lifting ships out of the water for repair and for launching new ship construction. The simplicity of this concept has allowed both large and small nations to benefit by increasing the efficiency and reducing the cost of shipyard operations.
- 2004** To **Josef Becker** for the invention, development, and worldwide implementation of the Rudderpropeller, a combined propulsion and steering system, which converts engine power into optimum thrust. As the underwater components can be steered through 360 degrees, the full propulsive power can also be used for maneuvering and dynamic positioning of the ship.

- 2005 To **Victor Wouk** for his visionary approach to developing gasoline engine-electric motor hybrid-drive systems for automobiles and his distinguished engineering achievements in the related technologies of small, lightweight, and highly efficient electric power supplies and batteries.
- 2006 To **Antony Jameson** in recognition of his seminal and continuing contributions to the modern design of aircraft through his numerous algorithmic innovations and through the development of the FLO, SYN, and AIRPLANE series of computational fluid dynamics codes.
- 2007 To **Robert Cook, Pam Phillips, James White, and Peter Mahal** for their seminal work and continuing contributions to aviation through the development of the Engineered Material Arresting System (EMAS) and its installation at many airports.
- 2008 To **Thomas P. Stafford, Glynn S. Lunney, Aleksei A. Leonov, and Konstantin D. Bushuyev** as leaders of the Apollo-Soyuz mission and as representatives of the Apollo-Soyuz docking interface design team: in recognition of seminal work on spacecraft docking technology and international docking interface methodology.
- 2009 To **Boris Popov** for the development of the ballistic parachute system allowing the safe descent of disabled aircraft.
- 2010 To **Takuma Yamaguchi** for his invention of the ARTICOUPLER, a versatile scheme to connect tugs and barges to form an articulated tug and barge, AT/B, waterborne transportation system operational in rough seas. His initial design has led to the development of many different types of couplers that have resulted in the worldwide use of connected tug and barges for inland waterways, coastal waters and open ocean operation.
- 2011 To **Zigmund Bluvband** and **Herbert Hecht** for development and implementation of novel methods and tools for the advancement of dependability and safety in transportation.
- 2012 To **John Ward Duckett** for the development of the Quickchange Movable Barrier.
- 2013 To **C. Don Bateman** for the development of the ground proximity warning system for aircraft.
- 2014 To **Bruce G. Collipp, Alden J. Laborde, and Alan C. McClure** for the design and development of the semi-submersible platform.
- 2015 To **Michael K. Sinnott** and the **The Boeing Company 787-8 Development Team** for pioneering engineering advances including lightweight composite wing and monolithic fuselage construction that have led to significant improvements in fuel efficiency, reduced carbon emission, reduced maintenance costs and increased passenger comfort.

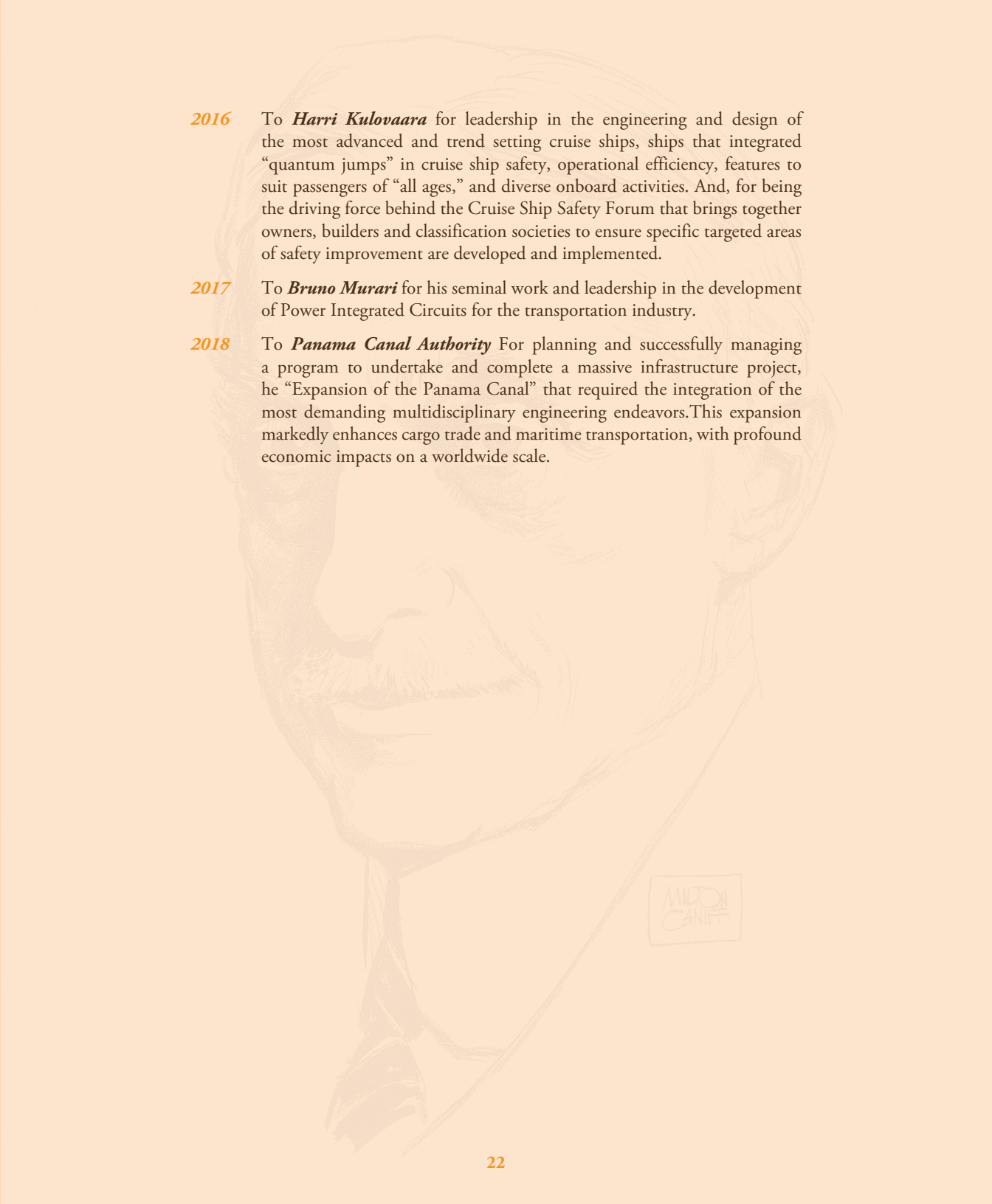
- 
- 2016** To *Harri Kulovaara* for leadership in the engineering and design of the most advanced and trend setting cruise ships, ships that integrated “quantum jumps” in cruise ship safety, operational efficiency, features to suit passengers of “all ages,” and diverse onboard activities. And, for being the driving force behind the Cruise Ship Safety Forum that brings together owners, builders and classification societies to ensure specific targeted areas of safety improvement are developed and implemented.
- 2017** To *Bruno Murari* for his seminal work and leadership in the development of Power Integrated Circuits for the transportation industry.
- 2018** To *Panama Canal Authority* For planning and successfully managing a program to undertake and complete a massive infrastructure project, he “Expansion of the Panama Canal” that required the integration of the most demanding multidisciplinary engineering endeavors. This expansion markedly enhances cargo trade and maritime transportation, with profound economic impacts on a worldwide scale.

The 2019 Elmer A. Sperry Board of Award

Thomas Hopkins, Chair
Roger D. Madden
Institute of Electrical and Electronics Engineers

Elizabeth Lawrence
George Hud
American Society of Mechanical Engineers

Mary Lang
Joseph Englot
American Society of Civil Engineers

Richard Miles
Prabhat Hajela
American Institute of Aeronautics and Astronautics

Edward L. Anderson
Art Vatsky
SAE International

George Williams
Naresh M. Maniar
Society of Naval Architects and Marine Engineers

Alternates

Richard Longman
American Institute of Aeronautics and Astronautics

Antonio Bastos
Institute of Electrical and Electronic Engineers

Eugene Sanders
Society of Naval Architects and Marine Engineers

The Sperry Award Board thanks Glenn Walters, SNAME Global Membership Chair and SNAME member of the Eastern Canadian Section, for developing the nomination for Sandy Thomson. Mr. Walters gave the presentation to the Board at the Board's March 13, 2019 meeting and the Board unanimously approved the award

Honorary Members

*Joseph U. Castellani
Richard W. Dawson
John M. Dempsey, Jr.*

*James Dolan
Bernard J. Eck*

*William A. Fife
Steward M. Frey*

*Harvey Glickenstein
Barney F. Gorin*

*Andrew W. Hermann
John L. Horton*

*Leon Katz
Philip Kimball*

*Clyde R. Kizer
Lev M. Klyatis*

*Bernard Koff
Eva Lerner-Lam*

*Stanley I. Mast
Gordon McKinzie*

*Leonard McLean
Aldo Nuzzolese*

*Robert Paaswell
William S. Peters*

*G. P. Peterson
Robert I. Price*

*George Pristach
Mario Ricozzi*

*Alan F. Rumsey
Eugene Schorsch*

*Carl S. Selinger
Miguel Torres-Castillo*

*John B. Walsh
Thomas F. Wholley*

*Clifford Woodbury
James R. Wittmeyer*

Secretary

David J. Soukup



2019